

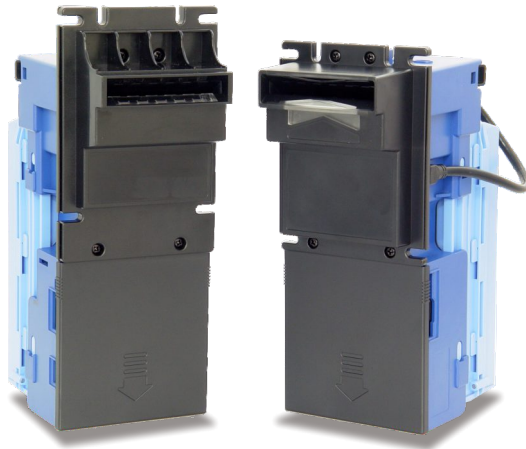

www.ictgroup.com.tw

Bill Acceptor

XBA Installation Guide



International Currency Technologies Corp.

Use of Materials Limitations

International Currency Technologies Corporation (ICT) all rights reserved.

All materials contained are the copyrighted property of ICT.

All trademarks, service marks, and trade names are proprietary to ICT.

ICT reserves the right at all times to disclose or to modify any information as ICT deems necessary to satisfy any applicable law, regulation, legal process or governmental request, or to edit, refuse to post or to remove any information or materials, in whole or in part, in ICT's sole discretion.

Contents

1. Introduction	
1-1. Overview.....	2
1-2. Features.....	2
2. Specifications.....	3
3. Packing List.....	4
4. Dimension.....	5
5. Installation	
5-1. Harness Application.....	7
5-1-1. I/O Circuit.....	17
5-2. DIP Switch Setting.....	22
5-3. Software Download and Upgrade.....	22
6. Maintenance.....	24
7. Troubleshooting	
7-1. Bezel LED Errors.....	25
7-2. Back LED Errors.....	26

1. Introduction

1-1. Overview

The XBA Bill Acceptor equips with innovative wide-angle banknote insertion technology to offer superior acceptance rate of 98% or higher. With the outstanding design, the XBA has the ability to provide very high degree of immunity to strong ambient light, and the advanced optical/ mechanical anti-fishing structure for better investment protection. The built-in USB port allows firmware upgrades via USB flash drive conveniently.

1-2. Features

- Auto-calibration, multi-color optical sensor.
- Allow bill insertion from very wide angle.
- Immune to strong ambient light.
- Advanced optical/mechanical anti-fishing structure.
- High MTBF.
- Support firmware upgrade through USB Flash Disk.
- Support Firmware upgrade through MDB-FTL.
- Works under severe weather condition.
- Support connect with Coin Changer.

2. Specifications

General

Acceptance Rate 98% or greater

Note: The incomplete bills such as extremely dirty, wet, broken or wrinkled ones are excluded.

Bill Insertion Four way acceptable

Transaction Speed Approx. 2.5 s to stack

Interface Pulse
MDB
ccNet
ccTalk
JPSTD
RS232 A0
ICT Protocol

Installation Indoor & Outdoor

Electrical

Power Source 12V DC $\pm 10\%$
24V DC $\pm 10\%$
24V/34V DC $\pm 10\%$
24V AC $\pm 10\%$

Power Consumption Standby : 0.15A, 1.8W
Operation: 1.0A, 12W
Maximum: 2A, 24W

Operation Environment Operating Temperature: $-20^{\circ}\text{C}\sim 60^{\circ}\text{C}$
Storage Temperature: $-30^{\circ}\text{C}\sim 70^{\circ}\text{C}$
Humidity: 30%~95%RH(no condensation)

Mechanical

Outline Dimension	Refer to page.5
Bill Capacity	Approx. 200 bills 400 bills 600 bills 1000 bills
Weight	Approx. 1.5kg
Bill Accepted Width	62~77mm

3. Packing List

Main	Bill Acceptor
Accessory	Harnesses: Refer to 5-1 XBA Installation Guide XBA Switches Setting Guide

4. Dimension

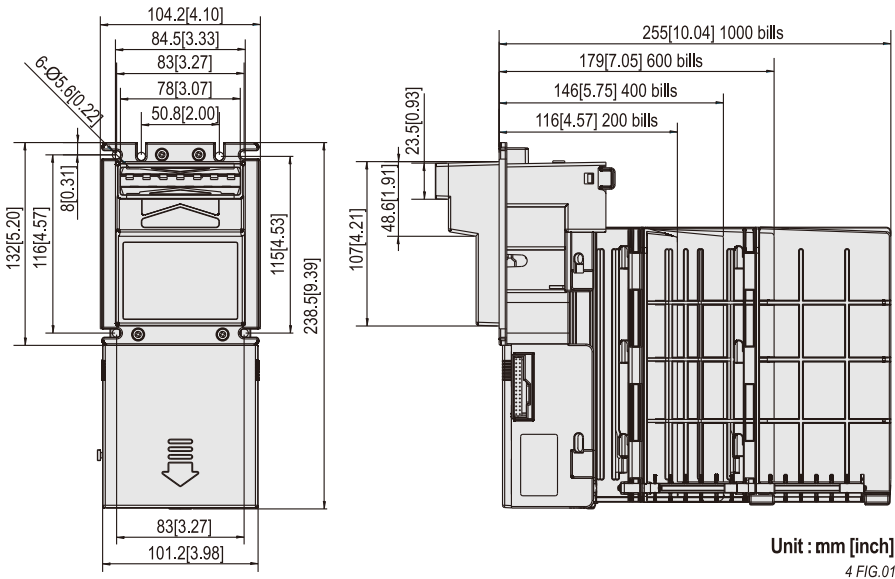

Bezel Style:

Standard plastic Bezel
Part No.3ZMB-FAC40000

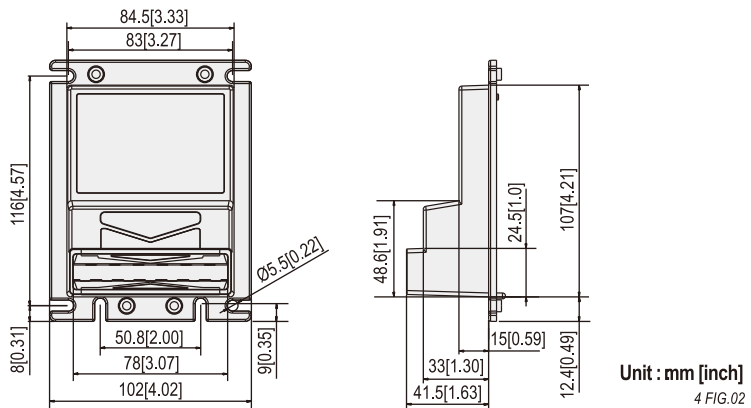

Two Side Bezel (Metal)
Part No. 3ZMB-FAC45000

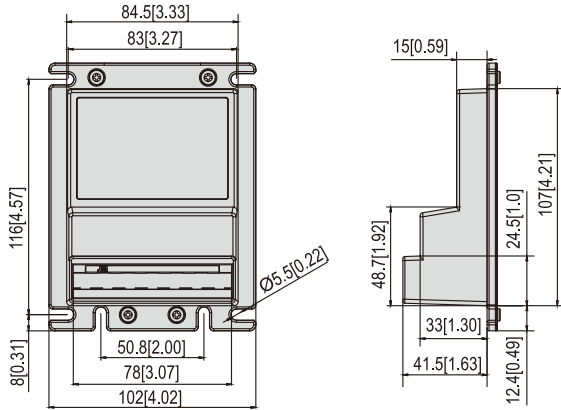

Unit : mm [inch]

4 FIG.02

TOB Bezel
Part No. 3ZMB-FAC41000

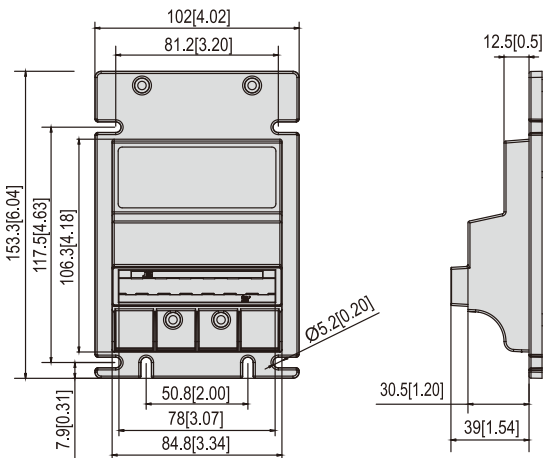

Unit : mm [inch]

4 FIG.03

5. Installation

5-1. Harness Application

5-1 TABLE 01

Interface	CPU Board	Used Voltage	Usage	Harness	Page
MDB	399Axx	24V/34V DC	Power & *Data comm.	WEL-RM006	8
		24V AC			
Pulse	399Axx and 399Mxx	12V DC	Power & *Data comm.	WEL-RV701	9
			Extension Wire	CU-R961-1	10
	399Axx	24V AC	Power & *Data Comm.	WEL-RV703	11
			Extension Wire	WEL-RV702	12
ICT Protocol	399Axx and 399Mxx	12V DC	Power & *Data Comm.	WEL-RXBA18-1	13
ccNet			Extension Wire	CU-R961-1	10
RS232 A0					
JPSTD	399Mxx	24V DC	Power & *Data comm.	WEL-RXBA20	14
ccTalk		** 12V/24V DC	Power & *Data comm.	WEL-RXBA21	15
USB Download	-	-	USB Extension Wire	WEL-RXBA31-2 (Optional)	16

* Date Comm.: Data Communication.

** ccTalk supports 12V/24V DC from CPU board number "399M30" (399M20 or before, support 12V DC only).

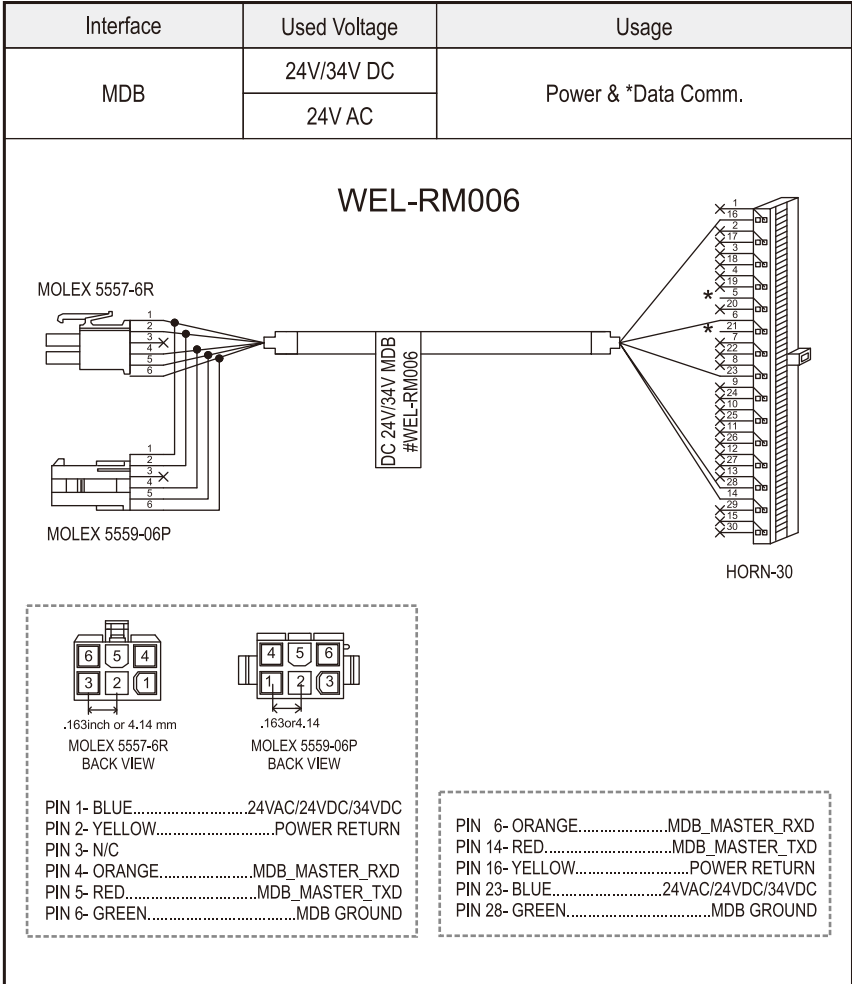

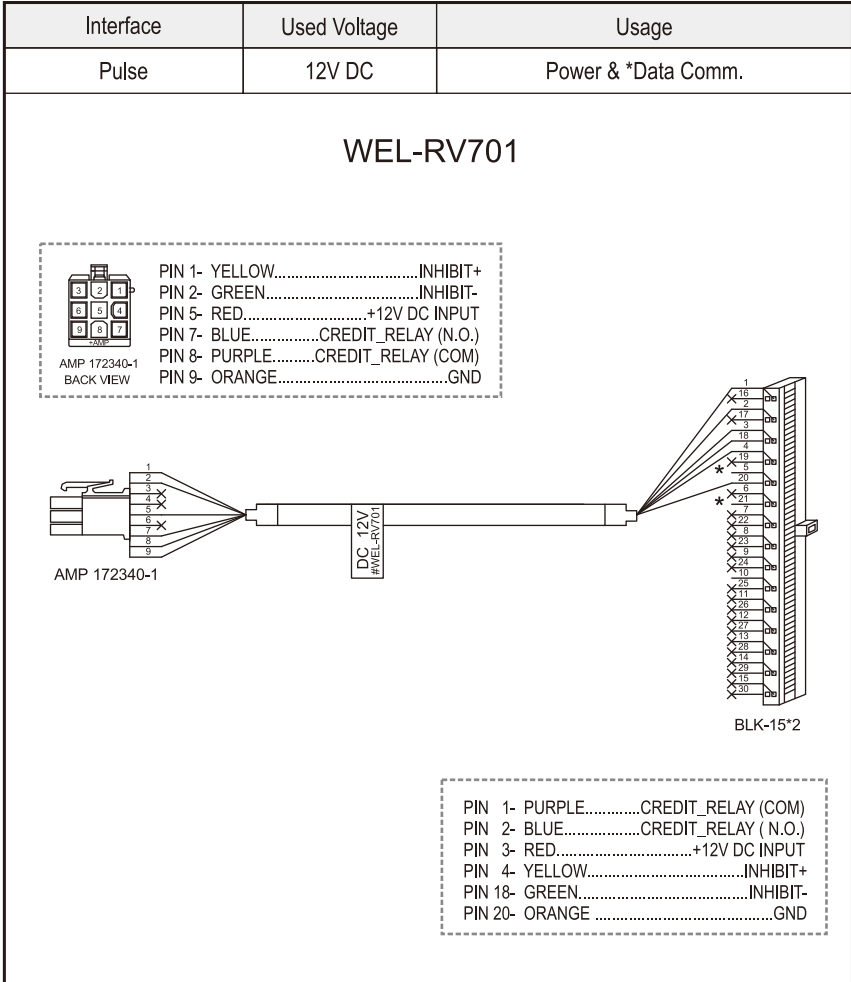

Interface	Used Voltage	Usage
Pulse	12V DC	Extension Wire for WEL-RV701
ICT Protocol	12V DC	Extension Wire for WEL-RXBA18
ccNet		
RS232 A0		

CU-R961-1

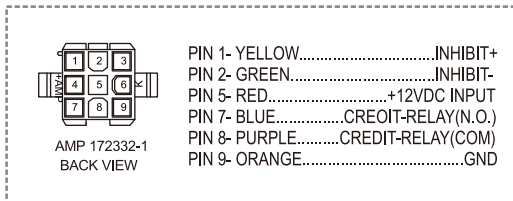
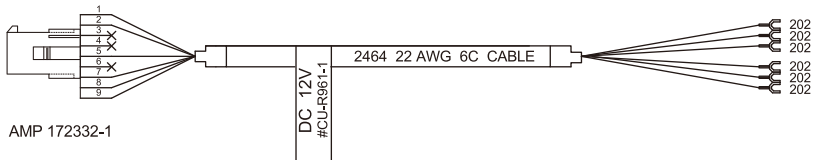

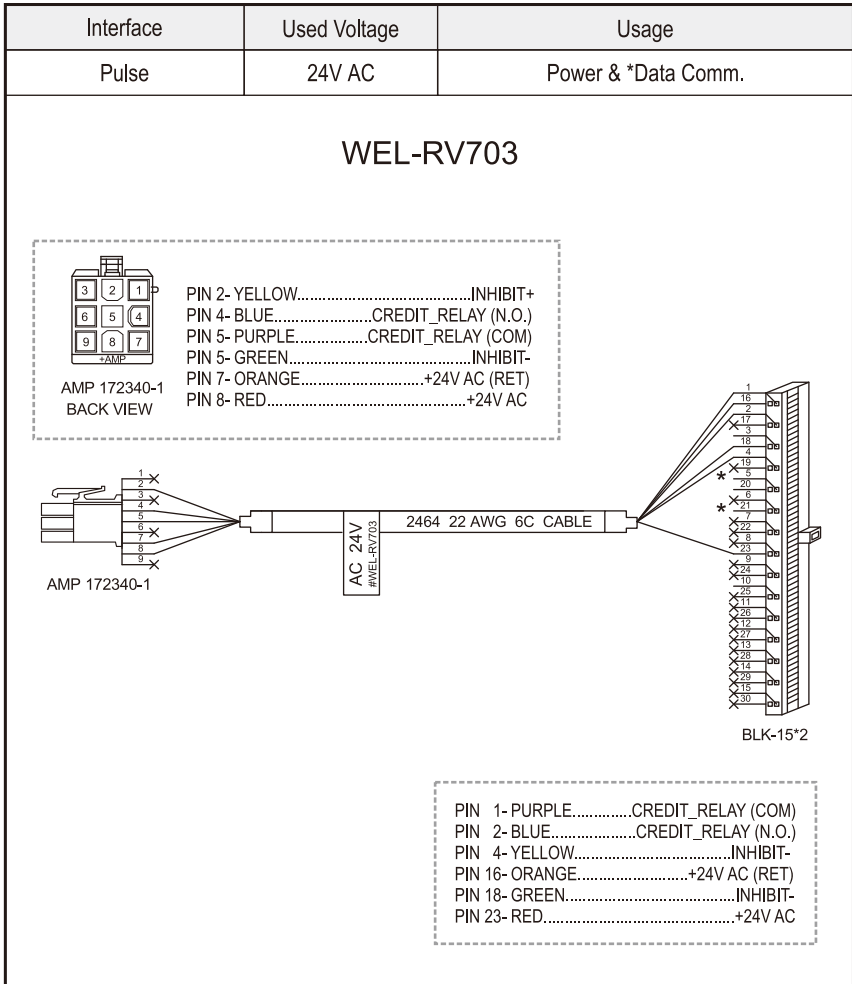

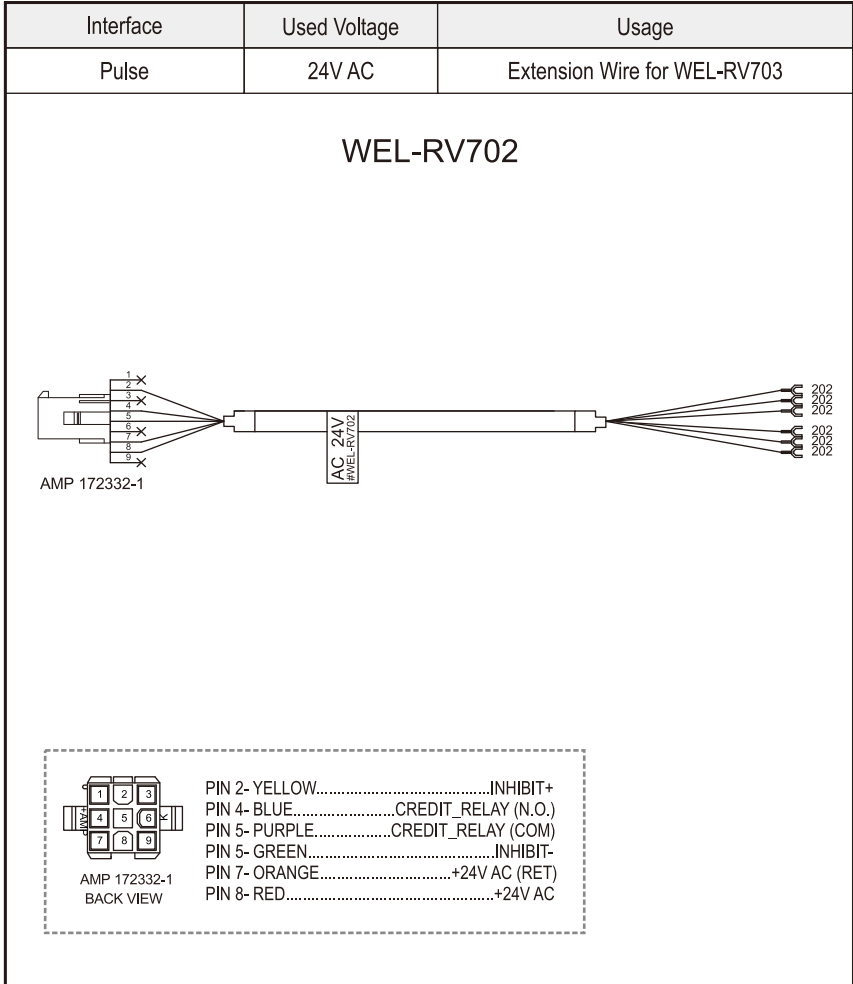

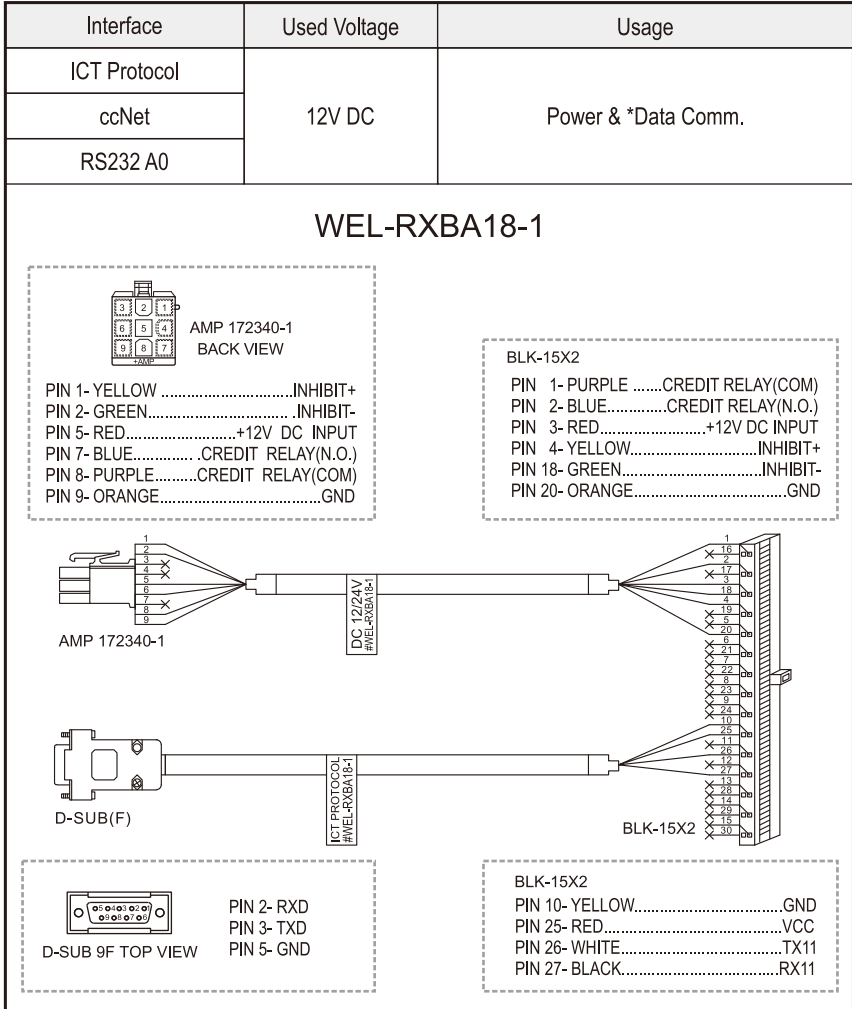

5-1 FIG.07

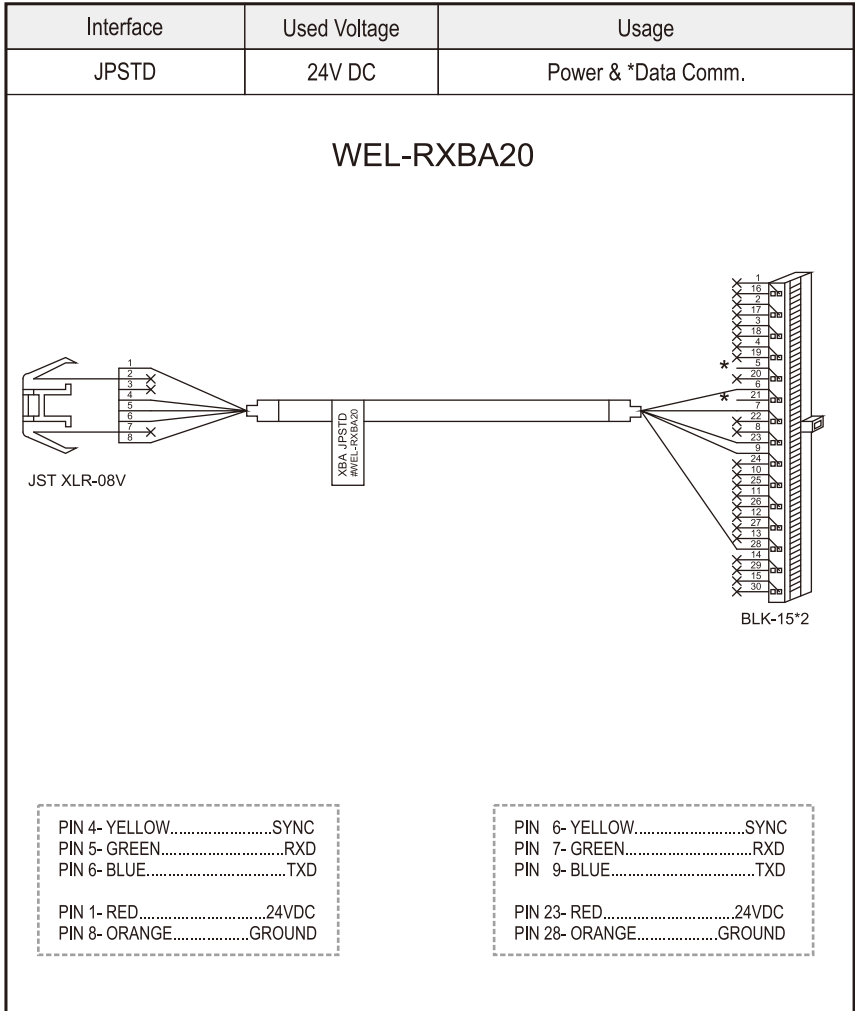

5-1 FIG.08

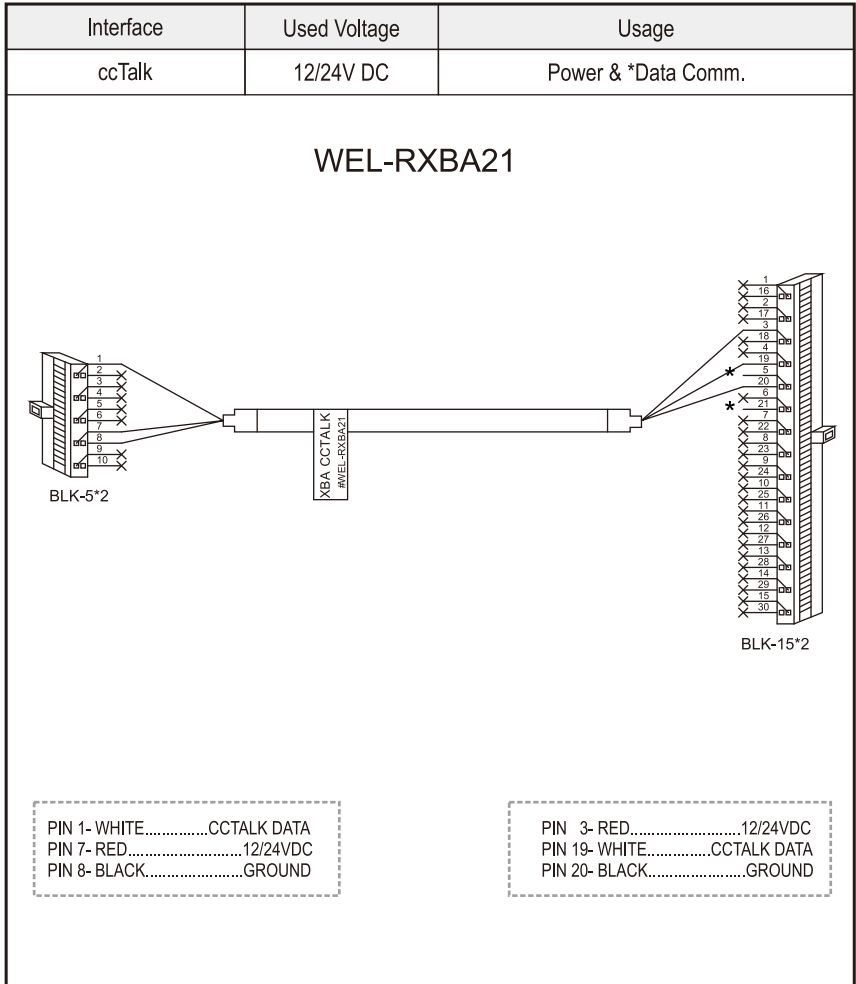

Note: XBA ccTalk supports 12/24V DC from CPU board number "399M30" (399M20 or before, support 12V DC only).

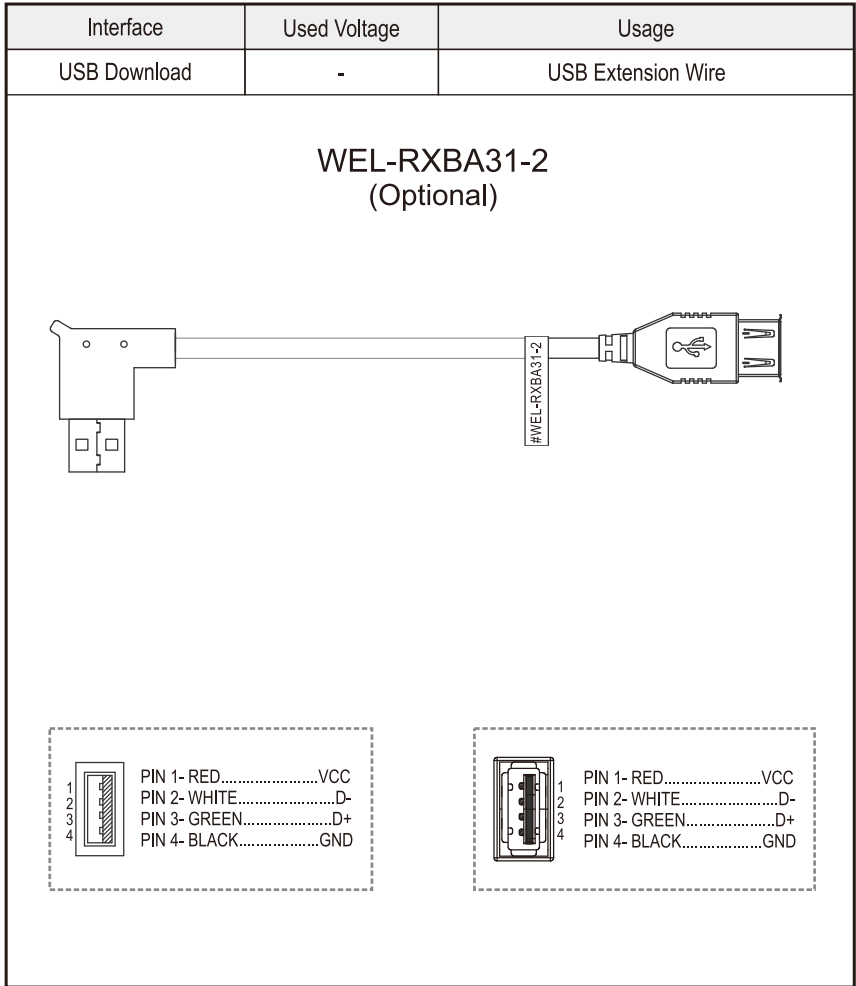

5-1-1. I/O Circuit

Pulse Interface

5-1-1 FIG.01

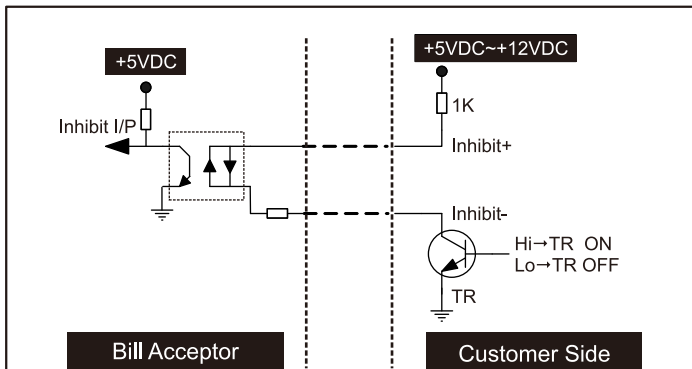
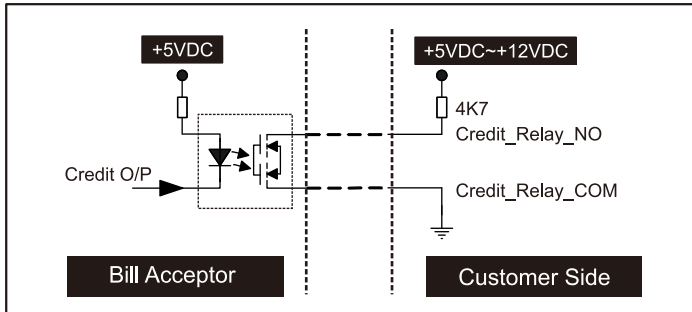

BA Status	DIP SW Setting		Control Signal
Inhibit	Inhibit Active	Low	Low
		High	High
Enable	Inhibit Active	Low	High
		High	Low

MDB Interface.

5-1-1 FIG.02

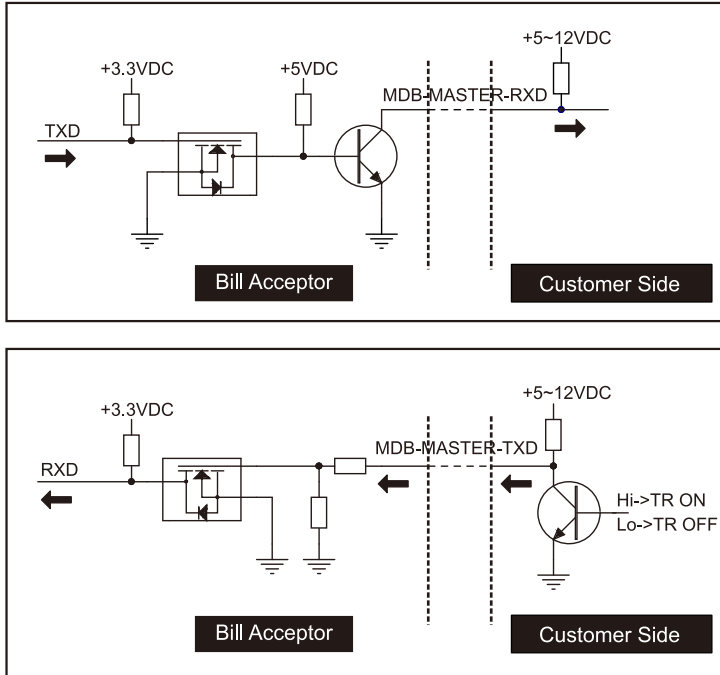

ICT-Protocol Interface.

5-1-1 FIG.03

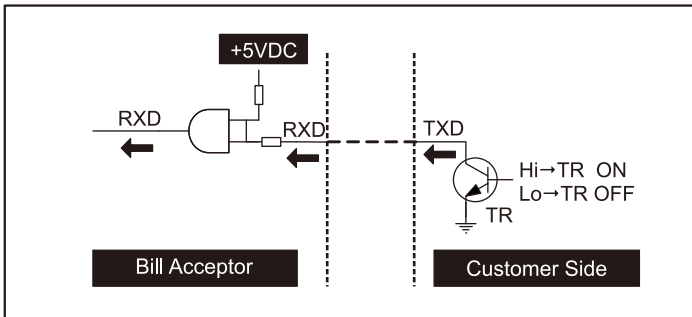
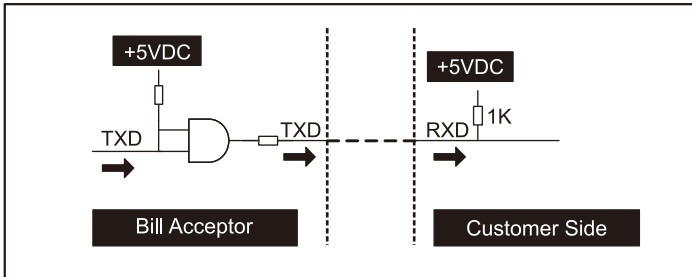

JPSTD Interface

5-1-1 FIG.04

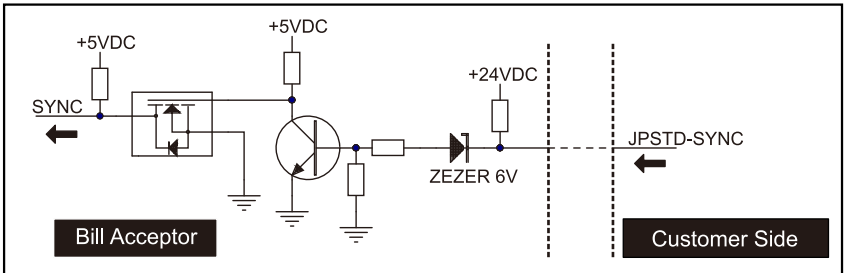
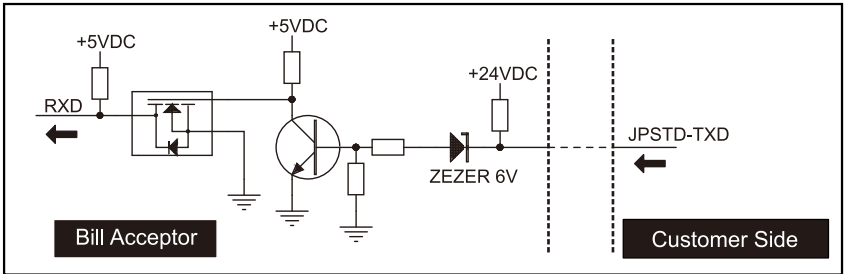
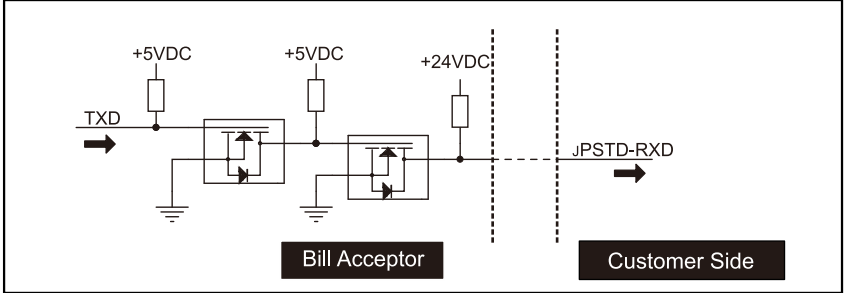

ccTalk interface

5-1-1 FIG.05

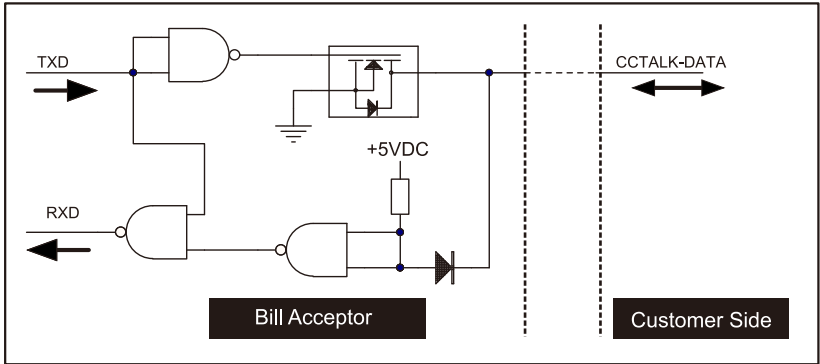

5-2. DIP Switch Setting

Two dip switches are located on as 5-2 FIG.01 the CPU board , and as 5-2 FIG.02 the sides of XBA.

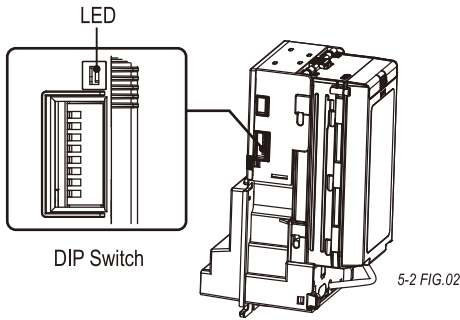
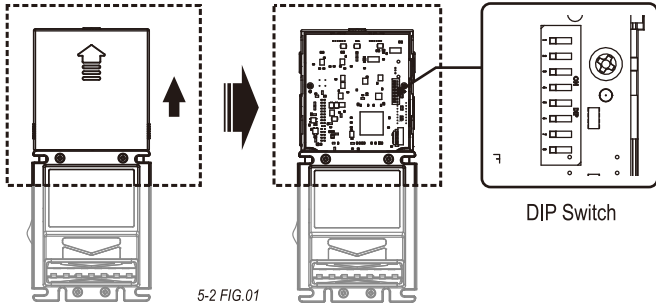

5-3. Firmware Download and Upgrade

Step 1. Put the "XBAXxx.bin" file into your USB Pen Drive.



Step 2.

Turn off XBA, plug the USB Pen Drive into the USB connector on the XBA and then turn on the XBA.

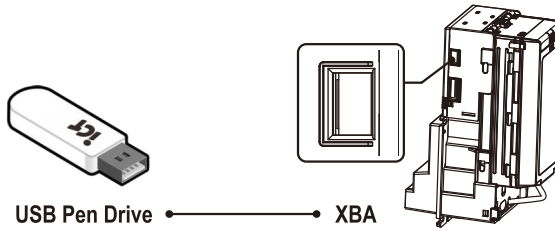

Step 3.

The LED in the rear side of bill insertion module will flash twice, then remove the USB Pen Drive from XBA.

Step 4.

Wait for about 30sec., then XBA will automatically reset and standby for normal operation.

6. Maintenance

To make sure the bill acceptor always works smoothly, please clean the internal parts regularly.

To clean the internal parts:

1. Press the buttons on the sides of bill path and pull the unit out.

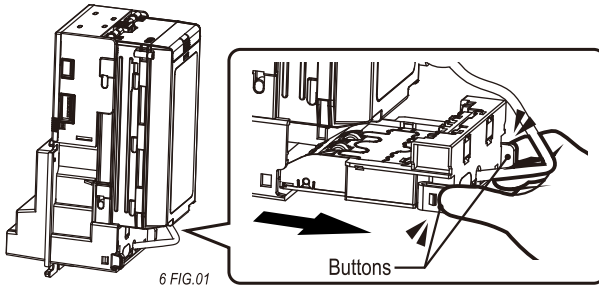

2. Use a soft, dry cloth or towel to clean the bill path and sensors.

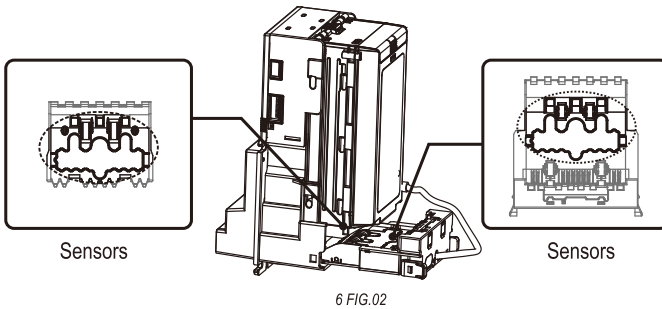

	Maintenance Notice (Any improper maintenance will result invalid warranty.)	
	Recommended	Mild, non-abrasive, soap water.
	DO NOT USE	Organic solvent , Alcohol, Volatility liquid.

7. Trouble Shooting

7-1. Bezel LED Errors

7-1 TABLE 01

LED Flashes		Status	Corrective Actions
RED	GREEN		
	1	White Card Calibration	Please calibrate with ICT white calibration card.
1		Bill jammed.	Remove the bill box by sliding the top button and the bill path (as 7-2 FIG.01), and then remove the jammed bill.
2		Disable.	Inspect the right DIP switch setting.
3		Recognition sensor module error.	Inspect the foreign objects on sensor or bill path and clean.
3	1	IR error.	Inspect the foreign objects on sensor or bill path and clean.
3+2		Hook sensor error.	Inspect the foreign objects on security hook and clean.
4		Anti-string sensor error or a stringing attempt has detected.	Inspect the foreign objects on sensor or bill path and clean.
5		Bill box has been removed.	Replace the bill box.
6		Stacker error or stacker full.	Empty the bill box.
7		Motor error.	Inspect the foreign objects on bill path and clean.

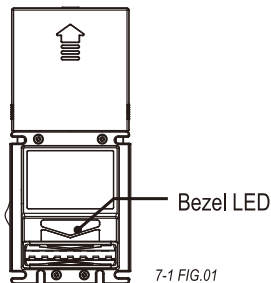

If the error can not be solved after corrective actions or it recurs, please contact ICT for technical support.

7-2. Back LED Errors

7-2 TABLE 01

LED Flashes	Status	Corrective Actions
RED		
1	White Card Calibration	Please calibrate with ICT white calibration card.
1	Bill jammed.	Remove the bill box by sliding the top button and the bill path (as 7-2 FIG.01), and then remove the jammed bill.
2	Disable.	Inspect the right DIP switch setting.
3	Recognition sensor module error.	Inspect the foreign objects on sensor or bill path and clean.
3+1	IR error.	Inspect the foreign objects on sensor or bill path and clean.
3+2	Hook sensor error.	Inspect the foreign objects on security hook and clean.
4	Anti-string sensor error or a stringing attempt has detected.	Inspect the foreign objects on sensor or bill path and clean.
5	Bill box has been removed.	Replace the bill box.
6	Stacker error or stacker full.	Empty the bill box.
7	Motor error.	Inspect the foreign objects on bill path and clean.

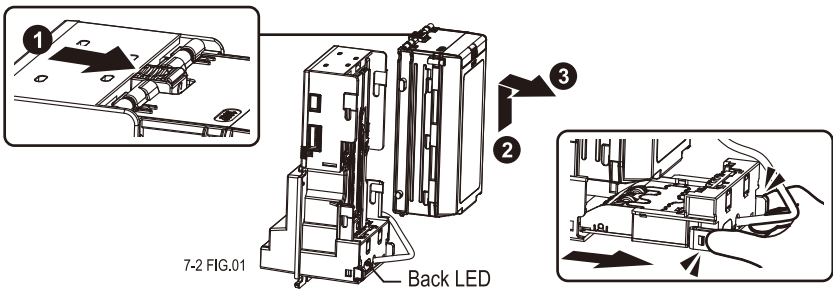

If the error can not be solved after corrective actions or it recurs, please contact ICT for technical support.

ict Taiwan

International Currency Technologies Corporation

No.28, Ln. 15, Sec. 6, Minguan E. Rd., Neihu Dist., Taipei City 114, Taiwan

sales@ictgroup.com.tw (For Sales)

fae@ictgroup.com.tw (For Customer Service)

Website: www.ictgroup.com.tw

